

RECOMMENDED PCB LAYOUT(TOP VIEW)
GENERAL TOLERANCE ±0.05

CKT	DIM A	DIM B	DIM C	DIM D	DIM E	DIM F
004	1.50	7.26	4.21	7.21	6.36	2.56
042	20.50	26.26	23.21	26.21	25.36	21.56

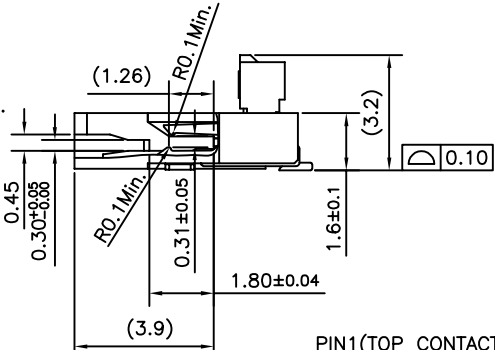

(ACTUATOR OPEN)

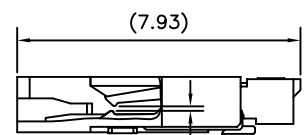

(ACTUATOR CLOSED)

- NOTES:
- MATERIAL:
 - HOUSING: THERMOPLASTIC, HIGH TEMP., UL94V-0; COLOR:NATURAL.
 - CONTACT: COPPER ALLOY
 - FITTING NAIL: COPPER ALLOY
 - ACTUATOR : THERMOPLASTIC, HIGH TEMP., UL94 V-0; COLOR:BLACK.
 - FINISH:
 - CONTACT:
 - 50u" MIN. NICKEL PLATING OVERALL.
 - M: 3u" MIN GOLD PLATING ON CONTACT AREA.
 - B: 5u" MIN GOLD PLATING ON CONTACT AREA.
 - T: 10u" MIN GOLD PLATING ON CONTACT AREA.
 - SOLDER:
 - M: GOLD FLASH PLATING ON SOLDER TAIL.
 - B: GOLD FLASH PLATING ON SOLDER TAIL.
 - T: GOLD FLASH PLATING ON SOLDER TAIL.
 - FITTING NAIL:
 - 50u" MIN. NICKEL PLATING OVERALL.
 - 80u" MIN. MATT TIN ON SOLDER TAIL
 - SPEC. PLS. REFER TO PS-51642-XXXX-XXX
 - PACKAGE PLS. REFER TO 51697-XXXX-XX-TRP
 - PART NUMBER

51697-XXX X X-XXX

CKTS PLATING

PACKING M: 3u" MIN. GOLD PLATING ON CONTACT
GOLD FLASH PLATING ON SOLDER TAIL
B: 5u" MIN. GOLD PLATING ON CONTACT
GOLD FLASH PLATING ON SOLDER TAIL
T: 10u" MIN. GOLD PLATING ON CONTACT
GOLD FLASH PLATING ON SOLDER TAIL

0: T&R

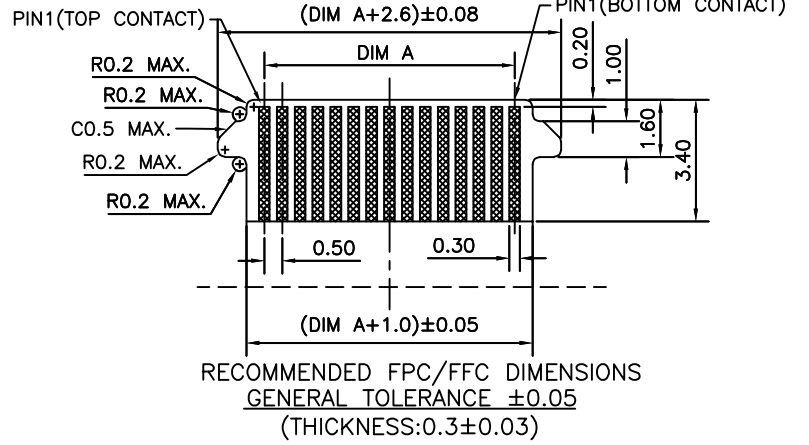

RECOMMENDED FPC/FFC DIMENSIONS
GENERAL TOLERANCE ±0.05
(THICKNESS:0.3±0.03)

QUALITY SYMBOLS	DRAWN BY	DATE	
MAJOR Ⓢ	Xu, Bin	22/06/17	
CRITICAL Ⓢ	CHECKED BY	DATE	TITLE 0.5mm PITCH EASY ON FPC SMT R/A D/C TYPE 1.6H
GENERAL TOLERANCES (UNLESS SPECIFIED)	Xu, Zhi Yong	22/06/17	
X. ±0.5	APPROVED BY	DATE	SIZE
.X ±0.25	Xu, Zhi Yong	22/06/17	A4
.XX ±0.15			SCALE
.XXX ±0.1			5 : 1
ANGLES ±2°			SHEET NO.
			1 OF 1
			REV
			F
			RFQ NO.
			PART NO.
			SEE NOTES
			DWG NO.
			51697-XXXX-XXX